



# Cambridge O Level

---

**PHYSICS****5054/32**

Paper 3 Practical Test

**May/June 2020****CONFIDENTIAL INSTRUCTIONS**

**This document gives details of how to prepare for and administer the practical exam.**

**The information in this document and the identity of any materials supplied by Cambridge International are confidential and must NOT reach candidates either directly or indirectly.**

**The supervisor must complete the report at the end of this document and return it with the scripts.**

---

**INSTRUCTIONS**

- If you have any queries regarding these confidential instructions, contact Cambridge International stating the centre number, the syllabus and component number and the nature of the query.  
email [info@cambridgeinternational.org](mailto:info@cambridgeinternational.org)  
phone +44 1223 553554

---

This document has **12** pages. Blank pages are indicated.

## General information about practical exams

Centres must follow the guidance on science practical exams given in the *Cambridge Handbook*.

### Safety

Supervisors must follow national and local regulations relating to safety and first aid.

Only those procedures described in the question paper should be attempted.

Supervisors must inform candidates that materials and apparatus used in the exam should be treated with caution. Suitable eye protection should be used where necessary.

### Before the exam

- The packets containing the question papers must **not** be opened before the exam.
- It is assumed that standard school laboratory facilities, as indicated in the *Guide to Planning Practical Science*, will be available.
- Spare materials and apparatus for the tasks set must be available for candidates, if required.

### During the exam

- It must be made clear to candidates at the start of the exam that they may request spare materials and apparatus for the tasks set.
- Where specified, the supervisor **must** perform the experiments and record the results as instructed. This must be done **out of sight** of the candidates, using the same materials and apparatus as the candidates.
- Any assistance provided to candidates must be recorded in the supervisor's report.
- If any materials or apparatus need to be replaced, for example, in the event of breakage or loss, this must be recorded in the supervisor's report.

### After the exam

- The supervisor must complete a report for each practical session held and each laboratory used.
- Each packet of scripts returned to Cambridge International must contain the following items:
  - the scripts of the candidates specified on the bar code label provided
  - the supervisor's results relevant to these candidates
  - the supervisor's reports relevant to these candidates
  - seating plans for each practical session, referring to each candidate by candidate number
  - the attendance register.

## Specific information for this practical exam

### Number of sets of apparatus

In addition to a few spare sets, the minimum number of sets of apparatus to be provided should be sufficient to enable candidates to spend 20 minutes with the apparatus for each of Questions 1, 2 and 3, and one hour with the apparatus for Question 4. The order in which candidates answer the questions will be determined by the supervisor. Candidates may spend one hour circulating around Questions 1, 2 and 3, followed by an hour on Question 4, or vice versa.

It is assumed that candidates will supply their own calculator and geometrical instruments, such as a set square,  $0^\circ$  to  $180^\circ$  protractor, pair of compasses and 30 cm ruler. Candidates should be advised in advance that they may, if they wish, use wrist-watches with stop-watch facilities, providing that such wrist-watches afford the required precision.

### Question 1

Items to be supplied by the centre (per set of apparatus, unless otherwise specified)

- power supply (see Note 1)
- five  $22\ \Omega$  resistors  $\pm 5\%$ , 2W (see Note 2)
- $100\text{ cm}^3$  beaker of internal diameter at least 4.5 cm
- stand with two bosses and two clamps
- switch or plug key
- ammeter capable of measuring a current of 1.0A to a precision of 0.01A or better. An analogue or digital meter is suitable
- voltmeter capable of measuring a potential difference of 5.0V to a precision of 0.1 V or better. An analogue or digital meter is suitable
- connecting leads and two crocodile clips
- thermometer  $-10$  to  $110\text{ }^\circ\text{C}$  to a precision of at least  $1\text{ }^\circ\text{C}$
- stop-watch reading to 0.1 s or better
- supply of water at room temperature
- paper towels to mop up any spillages.

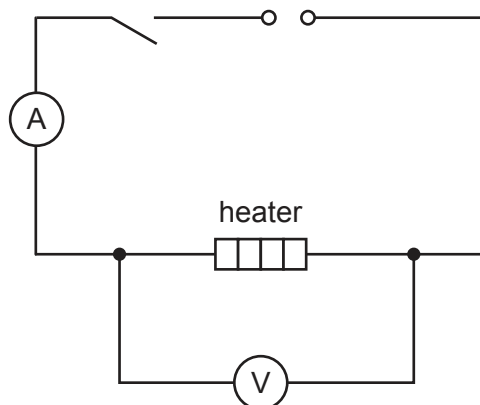

Fig. 1.1

### Notes

1. The power supply must be capable of supplying a current between 0.7A and 0.9A at a potential difference between 3.5V and 4.5V. The following are suitable power sources but all the candidates at a centre must be supplied with the same type of source.
  - d.c. power supply of 4.0V
  - three 1.5V dry cells in suitable holders connected in series
  - three 1.2V rechargeable cells in suitable holders connected in series.

- The supervisor should set up the circuit as shown in Fig. 1.1. The resistors must be arranged in parallel with ends twisted together, as shown in Fig. 1.2.



**Fig. 1.2**

- It must be possible for the candidate to submerge the heater in water inside a 100 cm<sup>3</sup> beaker of internal diameter at least 4.5 cm. The beaker must contain 50 cm<sup>3</sup> of water at room temperature. To prevent the beaker toppling over, it must rest on the base of the stand and be held in the jaws of a clamp attached to the stand. The second boss and clamp should be placed on the bench next to the thermometer.

At the changeover the supervisor should ensure that the circuit is in the configuration shown in Fig. 1.1 with the heater dry and the switch open. If cells have been used, ensure that they are still capable of providing the current and voltage described in Note 1 and replace if necessary.

The water in the beaker must be replaced with 50 cm<sup>3</sup> of fresh water from the supply.

Only the clamp holding the beaker should be attached to the stand (see Note 3). The second boss and clamp should be removed from the stand and placed on the bench next to the thermometer.

### **Information required by Examiners**

Sample set of numerical results, clearly marked “supervisor’s results”, obtained out of sight of the candidates.

## Question 2

Items to be supplied by the centre (per set of apparatus, unless otherwise specified)

- 3 biconvex lenses with 15 cm focal length (see Note 1)
- object A labelled A (see Note 2)
- half-metre rule with cm divisions
- small pieces of Blu Tack
- two slotted masses
- 30 cm ruler with mm divisions.

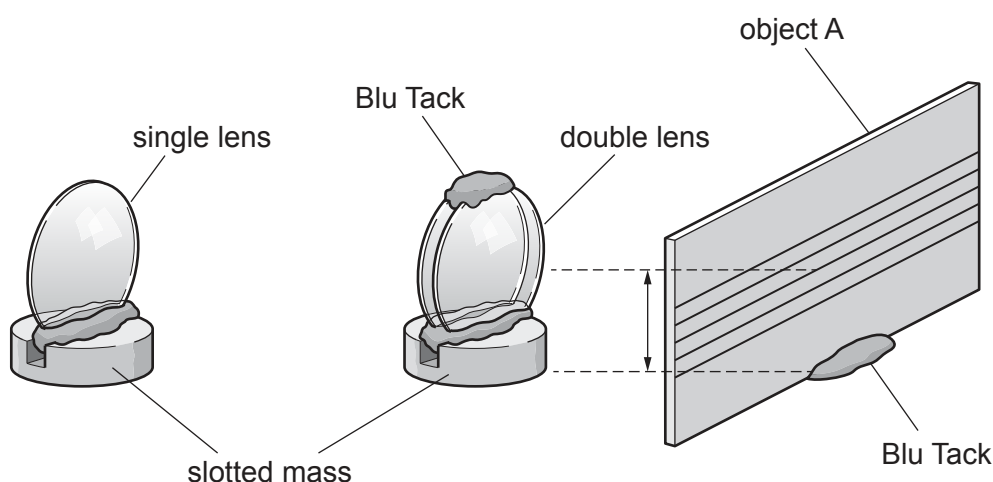

**Fig. 2.1**

## Notes

1. As shown in Fig. 2.1, a single lens should be mounted on one of the slotted masses using a piece of Blu Tack so that the lens is in the centre of the slotted mass and the plane of the lens is parallel with the slot of the slotted mass. In a similar way, the other two lenses should be mounted together on the other slotted mass so that they touch at the centre. An extra piece of Blu Tack should be used to fix these two lenses together at the top.
2. Object A may be made using a piece of rigid white card approximately 15 cm × 10 cm. Five horizontal parallel lines, 5.0 mm apart, should be marked on the card using a fine tipped (0.5 mm) pen. The centre of the five lines should be approximately level with the centre of the lens. A small piece of Blu Tack should be attached to one end of object A so that it is able to stand vertically on the half-metre rule without falling over as shown in Fig. 2.1.

At the changeover the supervisor should ensure that the lens arrangements and object A are placed side by side on the bench next to the half-metre rule.

## Information required by Examiners

Sample set of numerical results, clearly marked “supervisor’s results”, obtained out of sight of the candidates.

**Question 3**

**Items to be supplied by the centre (per set of apparatus, unless otherwise specified)**

- tennis ball, (see Note 1)
- metre rule, with mm divisions
- two set squares.

**Notes**

1. Candidates should be provided with one tennis ball, as new as possible. The tennis ball should have a diameter in the range from 6.5 to 6.9 cm. This type of tennis ball is covered in fibrous felt and has ridges as shown in Fig. 3.1.



**Fig. 3.1**

**Information required by Examiners**

Photograph of the ball or balls used, attached to the supervisor's report and labelled 'question 3'.

Sample set of numerical results, clearly marked "supervisor's results", obtained out of sight of the candidates.

### Question 4

#### Items to be supplied by the centre (per set of apparatus, unless otherwise specified)

- metre rule, with mm divisions, attached to a hook (see Note 1)
- smooth metal rod (e.g. a clamp) to act as a pivot (see Note 2)
- 2 identical expendable steel springs, with a spring constant of approximately 25 N/m, e.g. Philip Harris catalogue number B8G87194 (see Note 3)
- 100 g mass hanger and three 100 g masses
- loop of thread approximately 5 cm long
- half-metre rule with mm divisions
- 30 cm ruler
- stand and boss.

The supervisor must set up the apparatus as shown in Fig. 4.1.

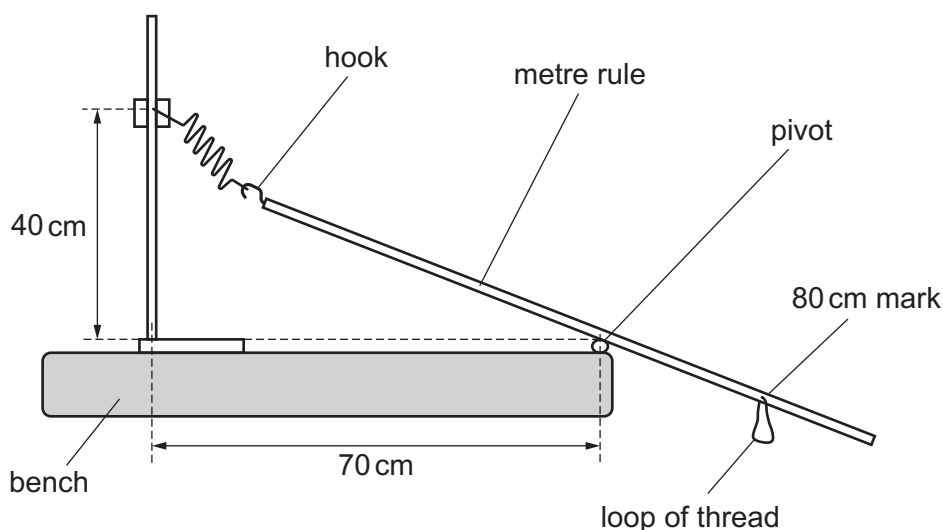

Fig. 4.1

#### Notes

1. A small hook should be screwed into one end of the metre rule. This hook will be attached to one end loop of one of the springs. The screw of the boss should pass through the other end loop of this spring, as shown in Fig. 4.2.

The boss should be attached to the stand 40 cm above the base of the stand. A small hole should be drilled through the metre rule at the 80.0 cm mark. A loop of thread should be passed through this hole so that a mass hanger can be attached as shown in Fig. 4.3.



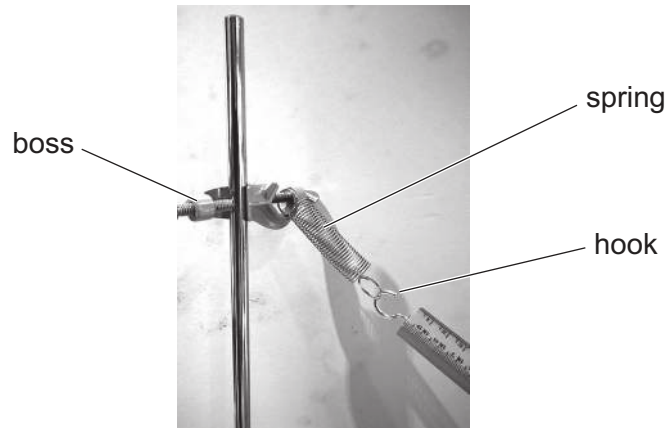

**Fig. 4.2**

2. A smooth metal rod should be placed horizontally on the bench, 70 cm from the rod of the stand. A suitable rod is the arm of a clamp. Pieces of Blu Tack can be used to hold the rod securely in place on the bench as shown in Fig. 4.3. The rod must be positioned so that the rule pivots on it and stays clear of the edge of the bench when a mass of 400 g is attached to the loop of thread. The stand may be secured in place using a G-clamp or a heavy weight.

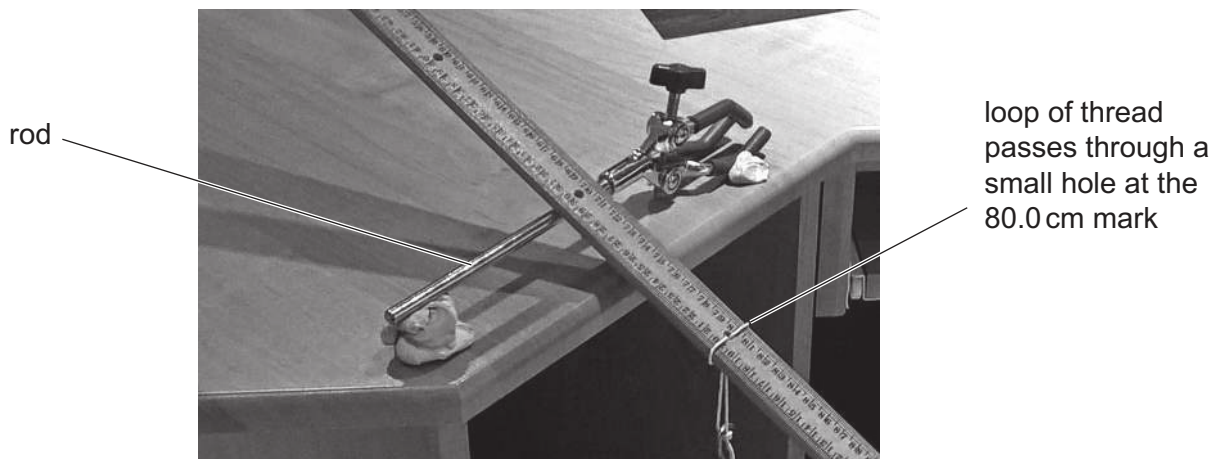

**Fig. 4.3**

3. One of the springs should be attached to the rod and boss as described in Note 1. The second, identical spring should be placed on the bench next to the 30 cm ruler.

At the changeover, the supervisor should ensure that the apparatus is returned to the configuration shown in Fig. 4.1, with the mass hanger and masses removed from the loop of thread.

### Information required by Examiners

Sample set of numerical results, clearly marked “supervisor’s results”, obtained out of sight of the candidates.

**BLANK PAGE**

---

Permission to reproduce items where third-party owned material protected by copyright is included has been sought and cleared where possible. Every reasonable effort has been made by the publisher (UCLES) to trace copyright holders, but if any items requiring clearance have unwittingly been included, the publisher will be pleased to make amends at the earliest possible opportunity.

To avoid the issue of disclosure of answer-related information to candidates, all copyright acknowledgements are reproduced online in the Cambridge Assessment International Education Copyright Acknowledgements Booklet. This is produced for each series of examinations and is freely available to download at [www.cambridgeinternational.org](http://www.cambridgeinternational.org) after the live examination series.

Cambridge Assessment International Education is part of the Cambridge Assessment Group. Cambridge Assessment is the brand name of the University of Cambridge Local Examinations Syndicate (UCLES), which itself is a department of the University of Cambridge.

**Supervisor's report**

Syllabus and component number

				/		
--	--	--	--	---	--	--

Centre number

--	--	--	--	--

Centre name .....

Time of the practical session .....

Laboratory name/number .....

**Give details of any difficulties experienced by the centre or by candidates (include the relevant candidate names and candidate numbers).**

You must include:

- any difficulties experienced by the centre in the preparation of materials
- any difficulties experienced by candidates, e.g. due to faulty materials or apparatus
- any specific assistance given to candidates.

### Declaration

- 1 Each packet that I am returning to Cambridge International contains the following items:
  - the scripts of the candidates specified on the bar code label provided
  - the supervisor's results relevant to these candidates
  - the supervisor's reports relevant to these candidates
  - seating plans for each practical session, referring to each candidate by candidate number
  - the attendance register
- 2 Where the practical exam has taken place in more than one practical session, I have clearly labelled the supervisor's results, supervisor's reports and seating plans with the time and laboratory name/number for each practical session.
- 3 I have included details of difficulties relating to each practical session experienced by the centre or by candidates.
- 4 I have reported any other adverse circumstances affecting candidates, e.g. illness, bereavement or temporary injury, directly to Cambridge International on a *special consideration form*.

Signed ..... (supervisor)

Name (in block capitals) .....